



Air Conditioning & Heating

CE COMMERCIAL
SERIES
50 Hz

Split System Air
Conditioners

7½ and 10 Ton

Nominal Cooling Capacity:
90,000 to 120,000 BTUH
[26.4 to 35.2 kW]

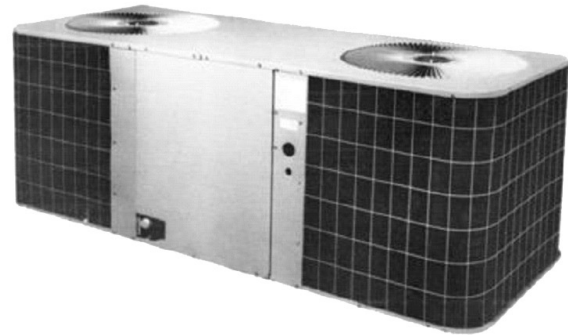

The CE Commercial 50 hz air conditioner is designed for ground level or rooftop applications. It may be used with evaporator blowers and coils

Standard Features

- Quiet operating top discharge
- Copper tube, aluminum fin coils
- Brass suction and liquid line shut-off valves
- Flare connections
- Totally enclosed permanently lubricated condenser fan motors
- Isolated compressor compartment
- High-efficiency performance
- Built-in fan cycle switch
- Hermetically sealed compressor
- Liquid line dryer
- Liquid line sight glass
- Low-pressure automatic reset control
- High-pressure manual reset control
- Internally protected compressor motor
- Dual condenser fans with divider to eliminate recirculation when only one fan is operating in mild ambient

Cabinet Construction

- Heavy-gauge, G-90 galvanized steel with removable access panels—completely weatherized, properly reinforced and braced
- Steel sheet metal is zinc-coated and galvanized by the hot dip process
- Weather-resistant, baked-on powder epoxy paint finish with 500-hour salt spray approval

Third-Party Tested

- Independent third-party performance tested with matching outdoor section by ETL Testing Laboratories, Inc., per ARI Standard 210-240

PRODUCT SPECIFICATIONS

Specifications

Model	Fan Diameter	Fan RPM	CFM	Tube Diameter	Face Area Ft ²	Rows Deep	Fins Per Inch	Fin. Ype	R-22 Holding Charge	Liquid Connection	Suction Connection	Approximate Shipping Weight— lbs. (kg)
CE090-5A	22" (2)	1,075	5,045	3/8"	34.75	1	19	RIPPLE	2 lbs.	5/8"	1 1/8"	403 (183.0)
CE120-5A	22" (2)	1,075	4,900	3/8"	34.75	1	19	RIPPLE	2 lbs.	5/8"	1 1/8"	416 (188.9)

Dimensions

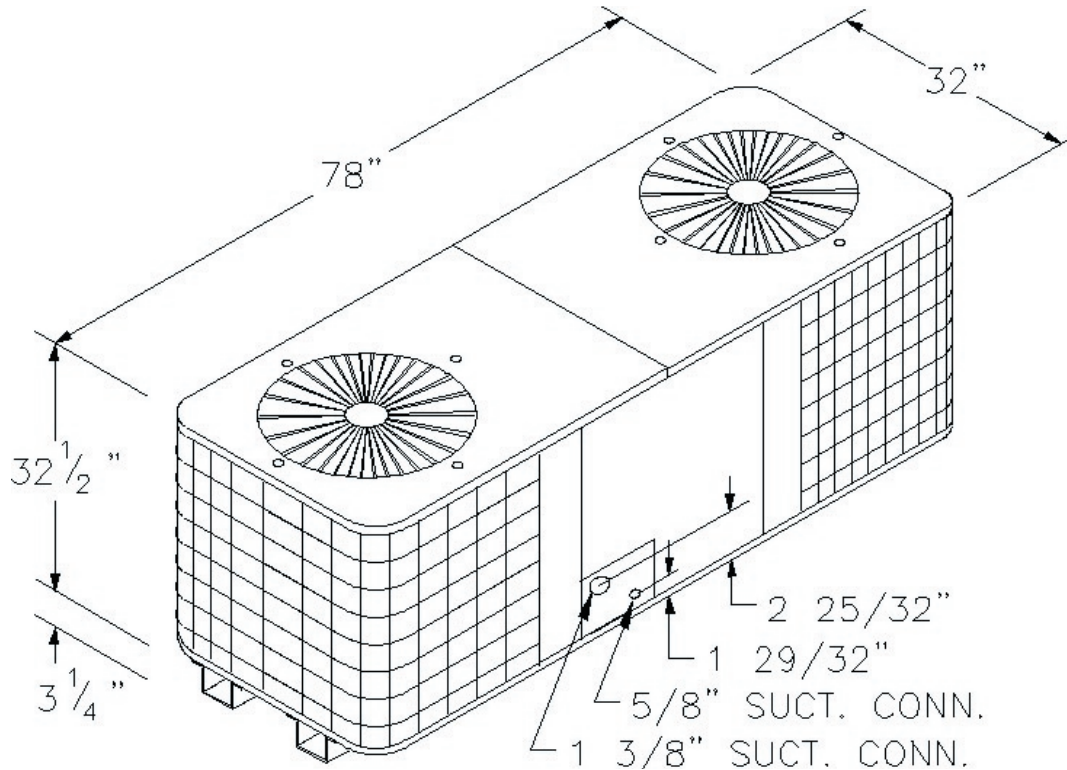

Ratings

Electrical Ratings

Model	Volts	Phase	Minimum Volts	*Minimum Wire Ampacity	Maximum Fuse Size	Compressor		Condenser Fan	
						FLA	LRA	FLA	HP
CE090-5A	415	3	380	20	30	14.4	119	1.2 (2)	1/3 (2)
CE120-5A	415	3	380	28	50	20.7	135	1.2 (2)	1/3 (2)

*Wire size should be in accordance with local electrical codes. Extensive wire runs require larger wire sizes.

Performance Ratings @ ARI Conditions

Model	Evaporator Model	Total BTUH @95 °F	Sensible BTUH @ 95 °F	kW	Sound Bels
CE090-5A	A90-00-2	85,690	63,100	9.56	8.8
CE120-5A	A120-00-2	108,780	81,200	13.38	8.8

PRODUCT SPECIFICATIONS

Expanded Performance Ratings

Outdoor Unit CE090-5A

INDOOR AIR		CONDENSER AIR TEMPERATURE														
		85			95			105			115			120		
SCFM	WB	Total MBTUH	Sens MBTUH	Watts kWh	Total MBTUH	Sens MBTUH	Watts kWh	Total MBTUH	Sens MBTUH	Watts kWh	Total MBTUH	Sens MBTUH	Watts kWh	Total MBTUH	Sens MBTUH	Watts kWh
2369	72	92.8	45.4	9.03	87.8	43.5	9.39	82.8	41.6	9.85	77.7	39.8	10.30	74.7	38.2	10.50
	67	84.4	56.8	8.39	80.3	54.9	8.84	75.2	53.0	9.30	70.2	53.0	9.75	67.5	50.8	9.77
	62	77.7	67.5	7.93	75.7	65.6	8.39	73.6	63.7	8.84	69.4	61.2	9.21	66.9	58.7	9.21
	57	75.2	71.9	7.75	71.9	68.8	8.21	67.7	65.0	8.75	64.4	61.2	9.12	62.0	58.7	9.12
2787	72	96.1	50.5	9.21	91.1	48.6	9.66	86.1	47.3	10.12	80.3	44.8	10.58	77.3	42.9	10.58
	67	88.6	65.0	8.66	83.6	63.1	9.12	78.6	61.2	9.57	73.6	59.3	10.03	67.7	56.8	10.23
	62	81.9	77.6	8.21	77.7	74.5	8.66	74.4	70.7	9.12	70.2	66.9	9.66	67.5	64.2	9.67
	57	81.1	78.2	8.21	77.7	74.5	8.66	74.4	70.7	9.12	70.2	66.9	9.66	67.5	64.2	9.67
3205	72	98.6	54.9	9.39	93.6	53.0	9.85	87.8	51.1	10.30	82.8	49.8	10.76	79.9	48.8	10.75
	67	91.1	72.6	8.84	86.1	70.7	9.30	81.1	68.1	9.75	76.1	66.3	10.21	73.4	63.6	10.22
	62	86.9	82.7	8.57	81.9	78.9	9.03	78.6	75.1	9.48	73.6	70.7	10.03	70.8	68.0	10.03
	57	86.9	82.7	8.57	81.9	78.9	9.03	78.6	75.1	9.48	73.6	70.7	10.03	70.8	68.0	10.03

Outdoor Unit CE120-5A

INDOOR AIR		CONDENSER AIR TEMPERATURE														
		85			95			105			115			120		
SCFM	WB	Total MBTUH	Sens MBTUH	Watts kWh	Total MBTUH	Sens MBTUH	Watts kWh	Total MBTUH	Sens MBTUH	Watts kWh	Total MBTUH	Sens MBTUH	Watts kWh	Total MBTUH	Sens MBTUH	Watts kWh
2838	72	117.2	51.3	12.86	110.9	49.1	13.38	104.5	47.0	14.03	98.2	44.9	14.68	95.0	43.8	15.00
	67	106.7	64.1	11.95	101.4	61.9	12.60	95.0	59.8	13.25	88.7	59.8	13.90	85.5	59.8	14.22
	62	98.2	76.2	11.30	95.6	74.0	11.95	92.9	71.9	12.60	87.6	69.1	13.12	85.0	67.6	13.38
	57	95.0	81.2	11.04	90.8	77.6	11.69	85.5	73.3	12.47	81.3	69.1	12.99	79.2	66.9	13.25
3153	72	121.4	57.0	13.12	115.1	54.8	13.77	108.8	53.4	14.42	101.4	50.6	15.07	97.7	49.1	15.39
	67	111.9	73.3	12.34	105.6	71.2	12.99	99.3	69.1	13.64	92.9	66.9	14.29	89.8	65.9	14.61
	62	103.5	87.6	11.69	98.2	84.0	12.34	94.0	79.7	12.99	88.7	75.5	13.77	86.1	73.3	14.16
	57	102.4	88.3	11.69	98.2	84.0	12.34	94.0	79.7	12.99	88.7	75.5	13.77	86.1	73.3	14.16
3784	72	124.6	61.9	13.38	118.3	59.8	14.03	110.9	57.7	14.68	104.5	56.2	15.33	101.4	55.5	15.65
	67	115.1	81.9	12.60	108.8	79.7	13.25	102.4	76.9	13.90	96.1	74.8	14.55	92.9	73.7	14.87
	62	109.8	93.3	12.21	103.5	89.0	12.86	99.3	84.7	13.51	92.9	79.7	14.29	89.8	77.3	14.68
57	109.8	93.3	12.21	103.5	89.0	12.86	99.3	84.7	13.51	92.9	79.7	14.29	89.8	77.3	14.68	

NOTES

1. KWI are net and includes compressor, condenser fan and evaporator fan consumption.
2. Sensible heat capacities shown are based on 80 °F DB (Dry Bulb) entering air at the evaporator coil.
3. For sensible heat capacities at other than 80 °F DB, deduct 84 BTUH per 100 CFM of evaporator coil air for each degree below 80 °F; or add 84 BTUH per 100 CFM of evaporator coil per degree above 80 °F.
4. All capacities are gross and include indoor motor heat (at outdoor 95 °F, indoor 75 °F DB and 63 °F WB). Indoor motor heat for CE090-5A is 4,700 BTU/HR; for CE120-5A is 9,000 BTU/HR.
5. SCFM = SUPPLY AIR FLOW (CFM); WB = ENTERING WET BULB TEMPERATURE; MBTUH= 1000 BTU/HR

PRODUCT SPECIFICATIONS

Schematic Wiring Diagram

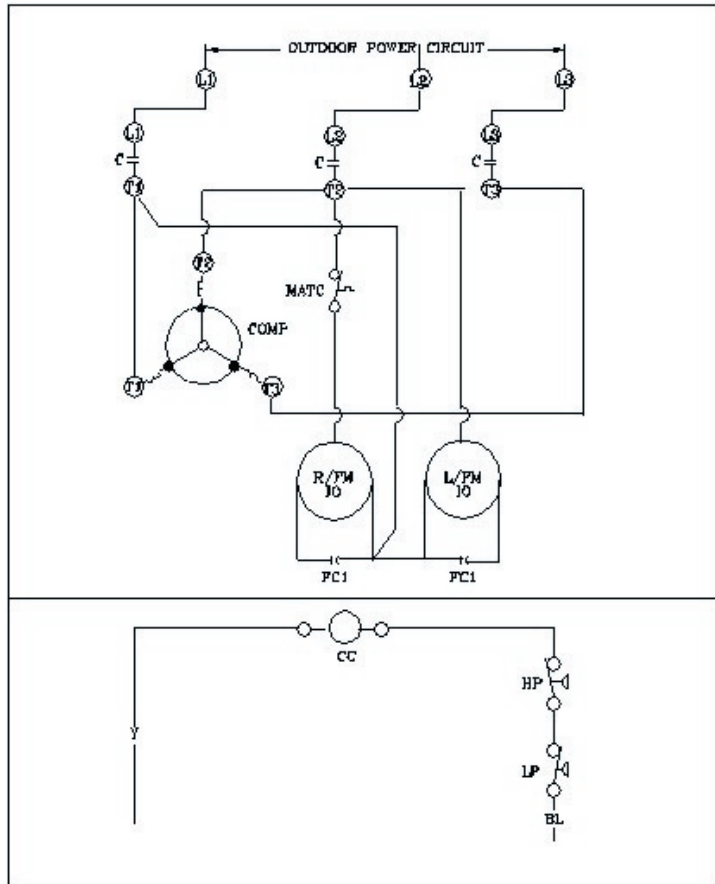

WIRE CODE

BL - BLACK
Y - YELLOW

COMPONENT LEGEND

C	CONTACTOR
CC	CONTACTOR COIL
COMP	COMPRESSOR
FC	FAN MOTOR CAPACITOR
HP	HIGH PRESSURE CONTROL
LP	LOW PRESSURE CONTROL
MATC	MILD AMBIENT TEMPERATURE
TB	TERMINAL BLOCK
L/FM	LEFT FAN MOTOR
R/FM	RIGHT FAN MOTOR
IO	INTERNAL OVERLOAD

Quality Makes the Difference!

All of our systems are designed and manufactured with the same high-quality standards, regardless of size or efficiency. We have designed these units to significantly reduce the most frequent causes of product failure. They are simple to service and forgiving to operate. We use quality materials and components. Finally, every unit is run-tested before it leaves the factory. That's why we know...there's no better quality.

Visit our web site at
www.goodmanmfg.com for information on:
 Goodman Products • Customer Services • Parts

Goodman Manufacturing Company, L.P.
 2550 North Loop West, Suite 400
 Houston, Texas 77092 USA

Goodman Manufacturing Company, L.P., reserves the right to discontinue, or change at any time, specifications or designs without notice or without incurring obligations.
 Copyright © 2003 Goodman Manufacturing Company, L.P. • Houston, Texas • Printed in the USA. • Goodman products are made proudly in the USA.