

PRODUCT SPECIFICATIONS



A COMMERCIAL SERIES

50 Hz
AIR HANDLER

7½ AND 10 TON

NOMINAL CAPACITY:
90,000 TO 120,000 BTU/H
[26.40 kW TO 35.30 kW]

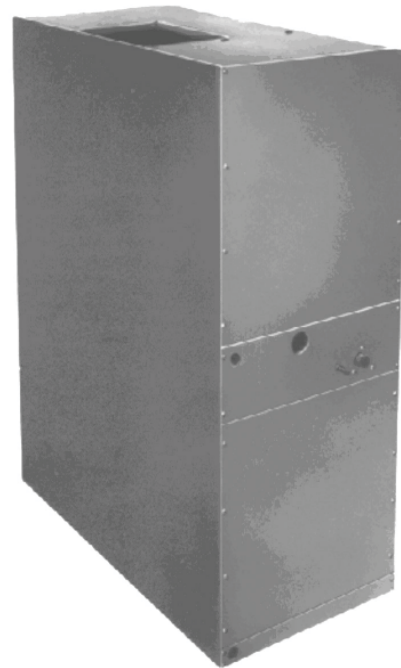

The A Commercial Series Air Handler is designed for upflow or horizontal application as well as for indoor use only.

Standard Features

- Thermal expansion valve (1) A90, (2) A120
- Dual circuitry on A120 for use with a 10-ton unit or two 5-ton condensing units
- Built-in horizontal and vertical oversized condensate pan to ensure proper drainage
- Cabinet fully insulated with fiberglass blankets
- Built-in filter rack
- Low-voltage and high-voltage entry on front panel
- Transformer, blower relay, and interlock relay are standard on every unit
- Copper tube, aluminum fin coil
- Belt-driven, low-noise, draw-through centrifugal blower for quiet, efficient operation

Accessories

- Room Thermostat (CHT90-120)

Cabinet Features

- Heavy-gauge, G-90 galvanized steel with removable access panels; properly reinforced and braced
- Insulation is supplied in sufficient thickness (1") and density to prevent condensate from forming on the unit casing
- Weather-resistant, baked-on powder epoxy paint finish with 500-hour salt spray approval

Third-Party Tested

- Independent third-party performance tested with matching outdoor sections by ETL Testing Laboratories, Inc., per ARI Standard 210-240



PRODUCT SPECIFICATIONS

SPECIFICATIONS

| | A90-00-2 | A120-00-5F |
|-------------------------------------|-----------------|--|
| Electrical | | |
| Unit Volts-Phase | 240-1 | 380-415-3 |
| Voltage Range | 198 - 264 | 342-435 |
| FLA (Total) | 10.6 | 3.3 |
| Ampacity (Wire Sizing) | 11.75 | 4.2 |
| Blower Motor Type | CAP.START | 3-Phase |
| HP | 1½ | 2 |
| Blower and Controls | | |
| Blower Wheel Diameter and Width | 12" x 12" | (2) 11" x 10" |
| Blower Pulley Pitch Diameter | 5½" | 6" |
| Bore | ¾ | 1.0 |
| Motor Pulley Pitch Diameter | 1.9" to 2.9" | 3.4" to 4.4" |
| Bore | ¾ | 7/8" |
| Belt Length and Width | 49" x ½" | 41" x ½" |
| Nominal Airflow (feet per minute) | 3,000 | 4,000 |
| Transformer (60 Vac.) | STANDARD | STANDARD |
| Interlock Relay | STANDARD | STANDARD |
| Blower Relay | STANDARD | STANDARD |
| Filter, Coil and Refrigerant | | |
| Filter, Replaceable | 32" x 47" x 1" | (2) 16" x 20" x 2" (2) 20" x 20" x 2" |
| Coil Area (ft ²) | 8.02 | 10 |
| Rows-fins Per Inch | 2-13 | 4-14 |
| Metering Device | Expansion valve | (2) Expansion valve |
| Liquid Connection | ⅜" | (2) ⅜" |
| Suction Connection | 1⅛" | (2) 1⅛" |
| Condensate Drain | ¾" FPT | ¾" FPT |

PERFORMANCE DATA

A90 Air Delivery*

| Airflow (ft ³ /min) | External Static Pressure (Inch Water Column) | | | | | | |
|-----------------------------------|--|---------|---------|---------|---------|---------|---------|
| | .1 | .2 | .3 | .4 | .5 | .6 | .7 |
| | Fan RPM | Fan RPM | Fan RPM | Fan RPM | Fan RPM | Fan RPM | Fan RPM |
| 2,800 | -- | -- | 800 | 830 | 850 | 880 | 945 |
| 2,900 | -- | 775 | 795 | 845 | 860 | 898 | 990 |
| 3,000 | -- | 800 | 830 | 850 | 880 | 930 | 1,010 |
| 3,100 | 790 | 830 | 848 | 865 | 895 | 960 | 1,020 |
| 3,200 | 810 | 840 | 850 | 880 | 930 | 1,000 | 1,030 |
| 3,300 | 850 | 890 | 880 | 895 | 965 | 1,020 | 1,060 |

* with dry coil and air filter

A120 Delivery*

| Air Delivery CFM (ft ³ /min) | Motor Sheave, Turns Open | | | | | |
|--|--------------------------|-------|-------|-------|-------|-------|
| Static Pressure (inches of water) | 0 | 1 | 2 | 3 | 4 | 5 |
| 0.2 | 4,845 | 4,530 | 4,280 | 4,264 | 4,000 | 3,750 |
| 0.3 | 4,773 | 4,430 | 4,127 | 4,087 | 3,830 | 3,600 |
| 0.4 | 4,608 | 4,280 | 3,944 | 3,879 | 3,780 | 3,390 |
| 0.5 | 4,451 | 4,075 | 3,779 | 3,700 | 3,565 | 3,137 |
| 0.6 | 4,235 | 3,886 | 3,580 | 3,506 | 3,325 | 2,850 |
| 0.7 | 4,060 | 3,680 | 3,392 | 3,274 | 3,058 | 2,570 |
| 0.8 | 3,850 | 3,477 | 3,163 | 3,024 | 2,700 | --- |
| 0.9 | 3,685 | 3,271 | 2,942 | 2,665 | --- | --- |
| 1 | 3,420 | 3,043 | 2,523 | 2,349 | --- | --- |

* with dry coil and air filter

Any adjustment made to the blower should not cause the motor to draw more than the motors rated RLA. Applications that exceed the above could require a larger motor.

PRODUCT SPECIFICATIONS

DIMENSIONS

MODEL A90

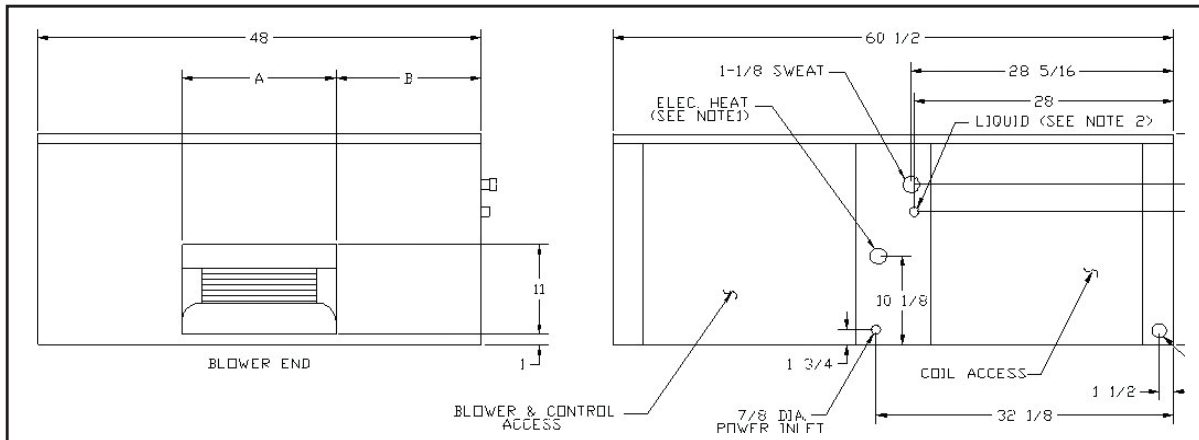

| MODEL | A | B |
|----------------------------|-------------|---------|
| A90 | 15 5/8" | 16 3/8" |
| Shipping Weight – lbs (kg) | | |
| A90-00-2 | 342 (155.3) | |

Notes:

- Concentric knockouts at 2, 1 3/4, 1 3/8
- A90-00, (1) 1/2 liquid line

MODEL A120

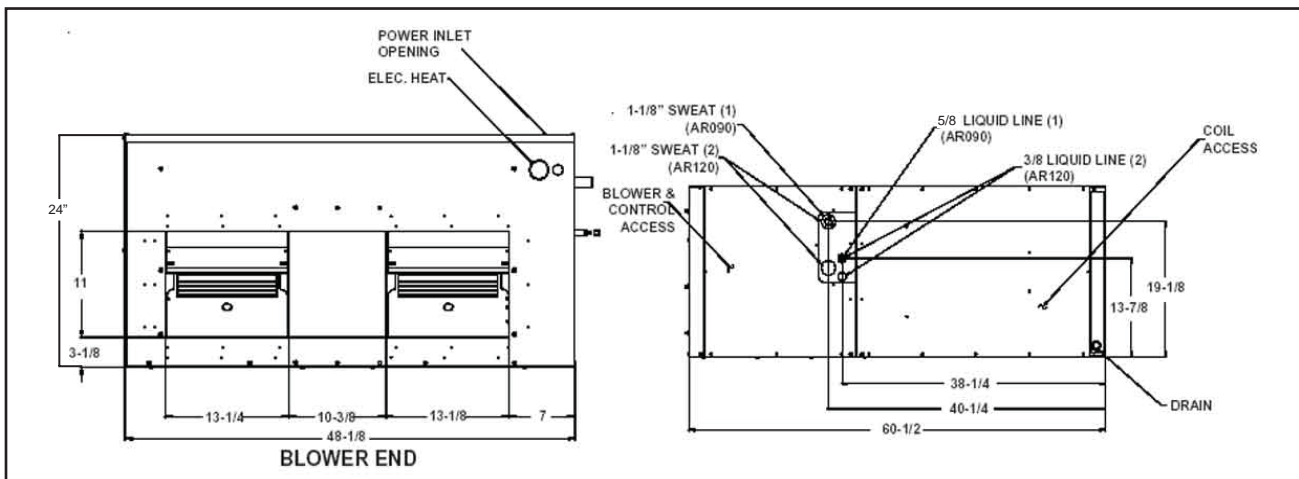

| Shipping Weight – lbs (kg) | |
|----------------------------|-----------|
| A120-00-5F | 430 (195) |

Notes:

- Concentric knockouts at 2, 1 3/4, 1 3/8
- A120-00, (2) 3/8 liquid line

DUCT CONNECTION SIZING

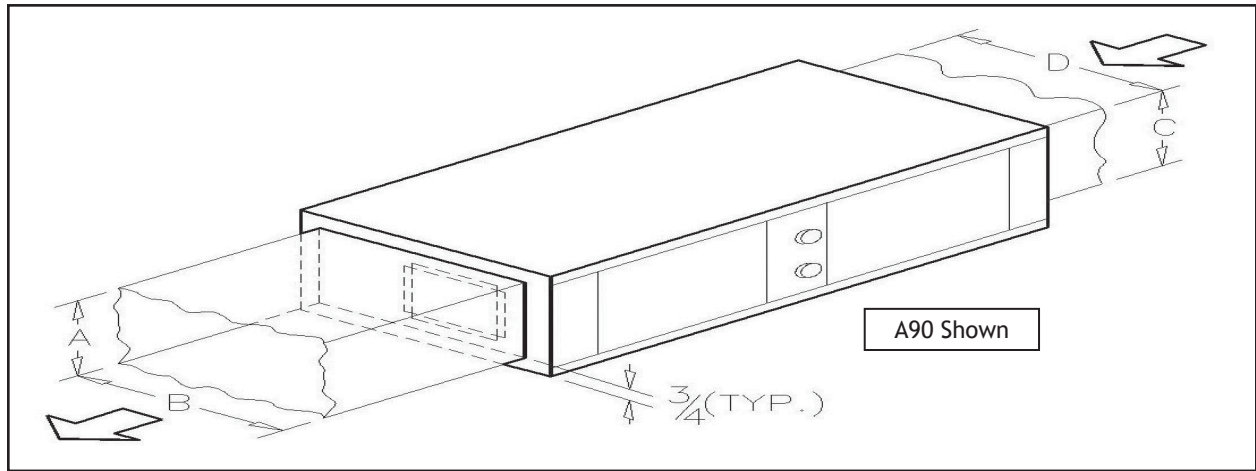

RECOMMENDED* MINIMUM SUPPLY AND RETURN DUCT DIMENSIONS

| Fan Coil Size | Supply Duct | | Return Duct | |
|---------------|-------------|-----|-------------|---------|
| | A | B | C | D |
| A90 | 11 1/2" | 34" | 22 1/2" | 46 1/2" |
| A120-00-5F | 13 1/8" | 40" | 24" | 48" |

Note: It is the installation technicians responsibility to size the duct work for each application.

Quality Makes the Difference!

All of our systems are designed and manufactured with the same high-quality standards, regardless of size or efficiency. We have designed these units to significantly reduce the most frequent causes of product failure. They are simple to service and forgiving to operate. We use quality materials and components. Finally, every unit is run-tested before it leaves the factory. That's why we know...there's no better quality.

Visit our website at
www.goodmanmfg.com for information on:
Goodman Products • Customer Services • Parts

Goodman Manufacturing Company, L.P.
2550 North Loop West, Suite 400
Houston, Texas 77092 USA

Goodman Manufacturing Company, L.P., reserves the right to discontinue, or change at any time, specifications or designs without notice or without incurring obligations.
Copyright © 2003 Goodman Manufacturing Company, L.P. • Houston, Texas • Printed in the USA. • Goodman products are made proudly in the USA.